

## **The Churchyard Regulations 2025**

*Within this leaflet, the Churchyard Regulations are set out in the left column with guidance in the right column, advising on good practice and management of our churchyards, and providing advice and assistance.*

November 2025

## INTRODUCTION

Churchyards have an important role in enabling the local church to support bereaved families.

The parish clergy are available to help you in deciding about where your loved one should be buried and the form of memorial they should have. It is important to understand that these Churchyard Regulations (“the Regulations”) are needed to govern how churchyards are managed. The Regulations are there to ensure that no one with a loved one buried in a churchyard is offended by what is introduced. Churchyards should be regarded as belonging to God, representing to us God’s love and compassion for the whole community, and available to the whole community.

Our churchyards are part of our Christian faith and heritage. They are owned by the Parish Priest of the parish alone. Through consecration they are set apart for the reverent burial of parishioners, that is, those who live in the parish, or have their names on the Electoral Roll or other persons who die in the parish. The Parish Priest may also grant permission for the burial therein of other persons at his or her sole discretion. There is no right of appeal from his or her decision on this point.

Parishioners (and other persons who die in the parish) have a right of burial in the churchyard, if one exists and provided that it has not been closed. The Parish Priest has the right to decide where in the churchyard a particular burial or interment shall take place. The only exception is where a specific place has been reserved by a legal permission (faculty) which is given by the Diocesan Chancellor.

In deciding to have a churchyard burial, the family is choosing to commit the remains of a loved one to the permanent care of the Church. The consecrated churchyard is therefore intended to be the last permanent resting place of the earthly remains of the deceased person.

Permission to install a memorial in the churchyard is overseen by the Chancellor via the faculty process. However, in the majority of cases, the Parish Priest is able to agree pre-approved memorials (that is, those that comply with the Regulations), under powers delegated by the Chancellor. If something is not permitted under the Regulations, the parish priest is not allowed to approve it.

Where there is a request for something not permitted by these Regulations then a petition for faculty can nonetheless be brought, given that the Chancellor retains the right to permit any type of tombstone or monument into the churchyard. Please note that this is not an “appeal” but it is a different process.

Permission for a memorial will normally only be granted for a person whose remains are buried or interred in the churchyard. The practice in churchyards may feel different from civil (local authority) cemeteries and burial grounds. In a churchyard, burial plots are not “owned” by the family. They remain part of the churchyard and as such are subject to these Regulations.

Churchyards need to be looked after and embellished to the glory of God, for the benefit of all of God’s people today as well as those to come. Some churchyards are maintained by contractors paid by the local church or the local authority; many churchyards are maintained by volunteers. It is important that they are able to maintain the churchyard for the benefit of families and other visitors. The Regulations are intended to encourage good practices in order to create and maintain a place of peace, dignity and respect for the departed, as well as a haven for wildlife.

## FEES

A table of statutory fees is published on the Church of England website: [Life events parochial fees and guidance | The Church of England](#)

## PREAMBLE

This document sets out the Chancellor’s Churchyard Regulations 2025 and Guidance, applicable in all parish churchyards of the Church of England in the Diocese of St Albans. This is the full version. It may be found at: [The Churchyard Regulations - The Diocese of St Albans](#)

A summary guide - *Churchyard Handbook – Guide for Families* is available from your parish priest or online at the Diocesan Registry address above.

*Within this leaflet, the Churchyard Regulations are set out in the **left** column with guidance in the **right** column, advising on good practice and management of our churchyards, and providing advice and assistance.*

## CONTENTS

INTRODUCTION.....	2
FEES.....	2
PREAMBLE.....	3
<b>Definitions.....</b>	<b>3</b>
<b>Procedure for obtaining permission to reserve a grave space or introduce a memorial.....</b>	<b>4</b>
<b>Details of memorials.....</b>	<b>7</b>
Headstones.....	7
Temporary items.....	10
Extensions to memorials.....	10
<b>Flowers, plants and wildlife.....</b>	<b>11</b>
<b>Smaller memorials for children.....</b>	<b>12</b>
<b>Burial of ashes.....</b>	<b>12</b>
Memorial Plaques.....	13
<b>Churchyard Maintenance and PCC responsibilities and powers.....</b>	<b>13</b>
<b>Discretionary Procedure.....</b>	<b>14</b>
<b>Exhumation.....</b>	<b>14</b>

## DEFINITIONS

<b>Archdeacon:</b>	Senior Priest working with the Bishop.
<b>Chancellor:</b>	The Judge of the Consistory Court.
<b>Diocesan Registrar:</b>	The diocesan legal advisor, also responsible for the administration of the Consistory Court on behalf of the Chancellor.
<b>Parish Priest:</b>	Rector, Vicar, Priest in Charge, Team Rector or Team Vicar.
<b>Rural (or Area) Dean</b>	Presides over a deanery, which is a group of parishes
<b>Diocese:</b>	The Diocese of St Albans covers Bedfordshire, Hertfordshire, Luton and Barnet, and is under the jurisdiction of the Bishop.
<b>Faculty:</b>	Special legal permission granted by the Chancellor of the Diocese.
<b>NAMM:</b>	National Association of Memorial Masons (or the British Register of Accredited Memorial Masons [BRAMM] or an equivalent industry body).

	<b>Regulation</b>	<b>Guidance</b>
1.1.	<b>In these Regulations</b> “Churchyard” includes any land consecrated for the interment of the remains of the dead, whether adjacent to a Church or not.	
1.2.	<b>All work</b> should be in accordance with these Regulations and any guidance for the time being approved by the Chancellor. In case of any doubt these Regulations shall prevail.	Authority in respect of memorials is vested in the Chancellor of the Diocese and disputed matters are referred to his or her court. Any departure from the Regulations requires faculty permission by the Chancellor, which will be decided on a case by case basis.
1.3.	<b>The powers</b> conferred by these Regulations on a Parish Priest may be exercised during any vacancy by the Area/Rural Dean. They may not be exercised by Churchwardens or other Sequestrators.	The Chancellor has granted delegated powers to Parish Priests (Rectors, Vicars, Priests in Charge, Team Rectors and Team Vicars). They have authority at their discretion to allow memorials into churchyards in a manner consistent with the Regulations. Where there is no parish priest, or the priest is absent, this authority is exercised by the Area/Rural Dean. They may consult with the Diocesan Advisory Committee (DAC) or the Chancellor.
1.4.	<b>These Regulations</b> apply throughout the diocese of St Albans. All work should comply with the code of working practice of NAMM insofar as compatible with the Regulations and the British Standard for memorial safety (BS8415).	

## **2. Procedure for obtaining permission to reserve a grave space or introduce a memorial**

	<b>Regulation</b>	<b>Guidance</b>
2.1.	<b>Permission for a reservation of a grave space</b> may be made in accordance with the practice set out in the Guidance.	<p>A grave space or ashes plot may be reserved by faculty, that is, with permission from the Chancellor’s court. There is no right to reserve a grave space. As a churchyard approaches capacity, it becomes less likely the Chancellor will grant an application to reserve. Informal local arrangements to reserve a grave space are not valid.</p> <p>In exceptional circumstances, permission may be granted at the discretion of the Chancellor, who may be sparing in her/his granting of faculties for reserved grave spaces. Reservation is a privilege not a right. The Parochial Church Council (“the PCC”) should pass a resolution and the applicant should apply for a faculty, paying the faculty fee. A contribution towards the funds of the PCC may also be required to meet expenses of maintenance and recording the reserved space. Reserved grave spaces should be marked with a wooden marker and logged in the church records. The cost of the stone should be paid by the applicant.</p> <p>Reservation is for the individual named on the faculty and is not transferable. The reservation is granted for a period of time fixed by the Chancellor. In each case this reflects the space remaining in the churchyard, the rate at which it is filling up, the number of plots already reserved and the rate</p>

	<b>Regulation</b>	<b>Guidance</b>
		<p>at which plots are being reserved. It is personal and limited to the lifetime of the applicant, meaning that the reservation cannot survive a person's death and thus cannot go to another person if unused, even if there is time remaining on the fixed term. If the person who has reserved a space is buried elsewhere, the reservation will lapse automatically, and the space may be used for another person.</p> <p>Guidance for clergy: If the churchyard is becoming full, the PCC should consider whether to adopt a policy in relation to reservation of grave spaces. The Chancellor will take any such policy into consideration in deciding individual applications.</p> <p>Neither the reservation of a grave space nor the exercise of the right of burial, nor the erection of a monument confers any right of ownership on the relatives of the deceased or upon any other person in respect of any part of the churchyard which remains owned by the Parish Priest.</p>
2.2.	<p><b>The introduction, renewal, removal, or alteration</b> of any tombstone or other monument must be dealt with in accordance with these Regulations.</p>	
2.3.	<p><b>No monument</b> shall be attached to, placed in churchyard walls or placed within 1220 mm (4ft) of any outer wall of any part of the church.</p>	<p>Burials (including burials of ashes) should not normally be close to a church or churchyard wall, as access may be needed e.g. to erect scaffolding for maintenance and repair.</p> <p>In the case of full burials, a small mound of earth will usually be left immediately after the interment. The grave will usually be marked by a simple wooden cross, no higher than 18". A time is prescribed to allow the grave to settle, and this will depend on local ground conditions. No application should be made for the introduction of a memorial, nor permission granted, until at least six months after the date of burial or in relation to cremated remains, six months from the date of cremation. The wooden marker should be removed as and when a permanent memorial is erected.</p>
2.4	<p><b>No tombstone or other monument</b> may be introduced, renewed, removed or altered without first obtaining permission. The family, or a funeral director or monumental mason on their behalf, should submit the application using a prescribed form CR1 or CR2 obtainable from the Parish Priest or online at link below.</p> <p>The application shall show full details of the design of the monument itself, of its materials, measurements, shape, colour, decoration and base, and the relationship of each part to the level</p>	<p>No action should be taken in respect of the application until written permission has been given. The applicant should not order the gravestone nor make arrangements for installation until permission has been given.</p> <p>If the information is incomplete, the application cannot be considered and will be returned.</p>

	<b>Regulation</b>	<b>Guidance</b>
	of the ground. It shall also show details of any inscription proposed, including the type, text, colour, style and size of the lettering.	
	<a href="#">Churchyard Forms - The Diocese of St Albans</a>	
2.5.	<b>If the Parish Priest</b> has power to authorise the proposed monument in accordance with this Schedule and sees fit to do so, then such authorisation shall be given in the prescribed form. If the application is not within the Parish Priest's power to grant, or the Parish Priest does not think fit to grant it, then the applicant shall be informed of this decision (and of his or her right to petition for a faculty authorising the proposed monument) in the form prescribed.	The family will own the memorial but do not 'own' the burial plot. It is the responsibility of the family to maintain a memorial in good repair, but churchyard memorials are expected to remain in place for up to 100 years and after a number of years, the family may no longer be able to maintain the memorial as they would wish. Safety is an important concern, and this is one reason why the Churchyard Regulations specify the type of memorial that is appropriate.
2.6.	If a <b>proposed memorial</b> falls outside the Churchyard Regulations the Chancellor may consider authorising it by faculty. Statutory fees are payable at the time of applying for a faculty. Full details are obtainable from the Diocesan Registry.	<p>People should see a memorial as an opportunity to make an individual statement about the deceased. The organisation Memorials by Artists, part of the Lettering Arts Trust <a href="#">Memorials — The Lettering Arts Trust</a> helps people to commission interesting individual memorials.</p> <p>The Diocesan Registry can be contacted at:  <i>St Albans Diocesan Registry</i>  <i>Winckworth Sherwood</i>  <i>Arbor 255 Blackfriars Road</i>  <i>London SE1 9AX</i>  <a href="mailto:stalbansregistry@wslaw.co.uk">stalbansregistry@wslaw.co.uk</a></p>
2.7.	<b>Existing churchyard monuments</b> should not be regarded as a precedent - this includes those in other dioceses and local authority cemeteries (which are subject to their own regulations), <b>as well as</b> other churchyards in the Diocese, a small number of which have bespoke regulations agreed by the Chancellor; and some individual monuments for which a faculty has been granted.	Memorials in a churchyard are intended to identify and commemorate those interred there. The right of a parishioner in a churchyard is confined to that of interment and any memorial must relate to the person/persons who is/are buried or whose cremated remains are interred in the grave. The erection of a memorial to a person or persons buried or interred elsewhere is not permitted except by faculty.

### 3. Details of memorials

	Regulation	Guidance
3.1.	To ensure that the memorial is properly and safely installed, it should normally be installed by members of the National Association of Memorial Masons or an equivalent body and must comply with the current British Standard (BS8415) for memorial safety.	
3.2.	<p><b>Monuments and memorials</b> shall be of natural stone (including sandstone, limestone, slates and granite) and non-reflective, or of oak. No monument shall be of black or pearl granite, of all-polished granite of whatever colour, of white marble, synthetic stone, plastic, or glass.</p>	<p>Natural materials only should be used, preferably those which are traditionally used in local buildings, e.g. stone, slate, or oak. The materials selected should be in sympathy with the colour and texture of the church building and its surroundings. Where possible the stone should be ethically sourced and processed, and evidence provided for approval by the parish priest. In cases where a mason is using up existing stock that does not comply, this should be brought to the attention of the parish priest, as faculty permission may apply. Environmental principles (effect on wildlife etc) should also be considered.</p> <p>In any individual churchyard the Parish Priest has authority at his or her discretion to allow the types of stone listed below (<u>underlined</u>).</p> <p><u>Sandstones</u> e.g. Forest of Dean, Serena (Italy), York  <u>Limestones</u> e.g. Hopton Wood, Hornston, Nabresina (Italy), Portland  <u>Slates</u> e.g. Welsh, Cumbrian  <u>Granites</u></p> <ul style="list-style-type: none"> <li>• may be grey or red and should be:</li> <li>• no lighter than honed Cornish and</li> <li>• no darker than honed Rustenberg Grey</li> </ul> <p><u>Marble</u> Dove Grey only</p> <p>For guidance, samples may be inspected at the Diocesan Office. The finish should be non-reflective to provide a setting that encourages a wide variety of lichens.</p> <p>For any other type, colour or finish of stone, permission should be sought in the first instance through the discretionary procedure in paragraph 8 below.</p>
3.3.	<p><b>a) Headstones</b> shall not exceed 1200mm (4ft) in height, measured from the ground level, 900mm (3ft) in width and 150mm (6") in thickness. They shall not be less than 600mm (2ft) high, 500mm (1'8") wide and 65mm (2½") thick (unless slate is used, in which case they shall not be Less than 50mm (2") thick). Responsibility for erecting a headstone that is safe and stable</p>	<p>Headstones or crosses, provided they fall within the Regulations, may be introduced and should be of traditional shape and of simple design.</p> <p>So far as adjacent ground levels reasonably permit, the foundations of a headstone or cross should be at or below the surface of the ground so that a mower may pass freely over it. They should be so constructed and placed as to ensure safety and stability.</p>

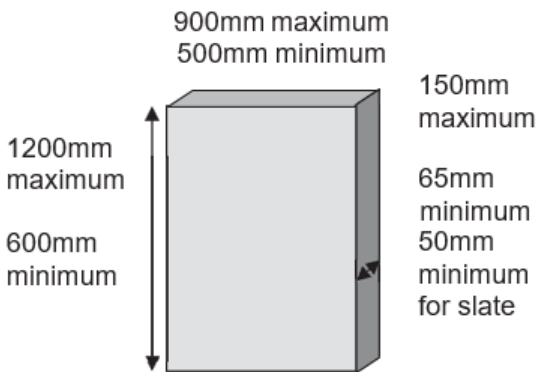
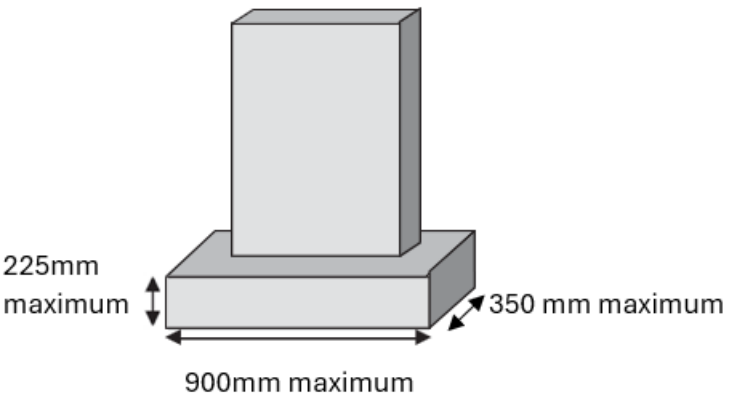
	Regulation	Guidance
	<p>rests with the monumental mason. Headstones may be of three types:</p> <ul style="list-style-type: none"> <li>• so shaped that they can be inserted directly into the ground at sufficient depth to ensure stability, in which case the memorial will be inserted into a concrete shoe underground</li> <li>• on an integral base no more than 900mm (3ft) wide and not more than 225mm (9") high. The base shall be no more than 350mm (1'2") overall front to back.</li> <li>• a vase base incorporating one or two vases, not more than 900mm (3ft) wide or more than 100mm (4") high. The base shall not be more than 375mm (1'3") overall from front to back.</li> </ul> <p><b>b) Crosses.</b> The height of a cross, measured from the ground level, shall not exceed 1370mm (4'6") nor be less than 750mm (2'6"). The width shall not exceed 600mm (2ft) or be less than 300mm (1ft). The thickness of the shafts and arms shall not exceed 150mm (6") or be less than 65mm (2½").</p> <p>No cross should stand on more than two steps. The step, or lower of the two steps, shall measure no more than 600mm (2ft) in width and 300mm (1ft) from front to back. The steps may be replaced by a boulder, but the above measurements shown for the steps still apply. The height of a cross is to be calculated inclusive of the height of any steps and should not exceed the maximum sizes for a headstone in any dimension.</p> <p><b>c) Horizontal Slabs or Plaques</b> (over burials) are not permitted as these impede the maintenance of the churchyard.</p> <p>No monument shall include any columbaria (stone urns), kerbs, railings, slabs, plain or coloured chippings, artificial grass, statuary, sculpture or figures, sun dials, bird baths, fencing or obelisks</p>	<p>Headstones should be within the permitted sizes. Different dimensions are specified for slate.</p> <p>Headstones may be of three types:</p> <ul style="list-style-type: none"> <li>• so shaped that they can be inserted directly into the ground at sufficient depth to ensure stability</li> <li>• on an integral base</li> <li>• on a vase base</li> </ul> <p>For details of smaller memorials for babies and children, please see Section 5 below.</p> <ul style="list-style-type: none"> <li>• If you wish to have one or two flower vases set into the base of the memorial this will be permitted, but you cannot have more flower vases and the vase or vases cannot be separate from the memorial, unless you do not intend to have a headstone or memorial. A single vase or two symmetrical vases can be set into the headstone base and can extend a maximum of 205mm in front of the headstone. Note that flowers may obscure the headstone inscription.</li> </ul> <p>Artificial turf prevents the grave mound subsiding by natural weathering and is a maintenance hazard.</p> <p>Examples of memorial sizes are set out below (for illustrative purposes only):</p> <div style="text-align: center;">  <p>900mm maximum 500mm minimum</p> <p>1200mm maximum 600mm minimum</p> <p>150mm maximum 65mm minimum 50mm minimum for slate</p> </div> <p><b>Integral base:</b></p> <div style="text-align: center;">  <p>225mm maximum</p> <p>900mm maximum</p> <p>350mm maximum</p> </div>

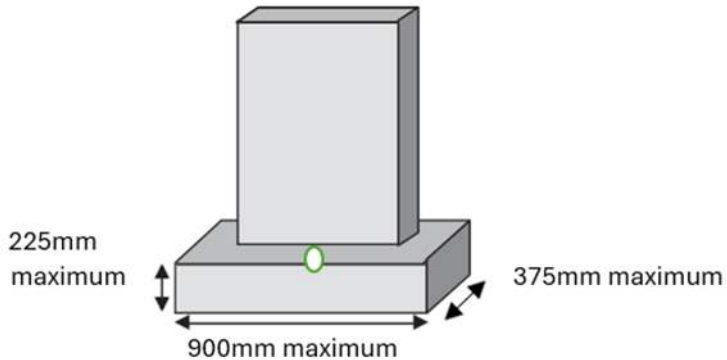
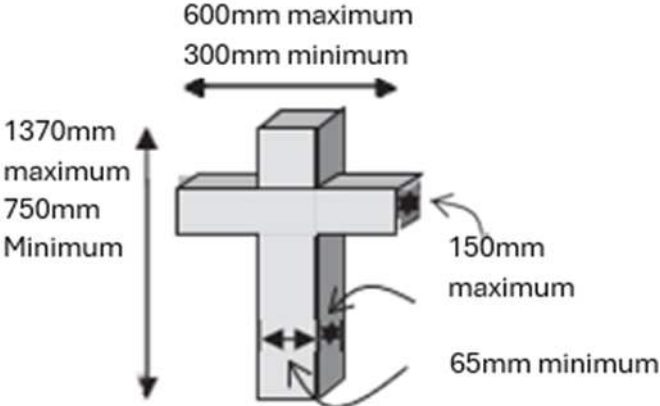
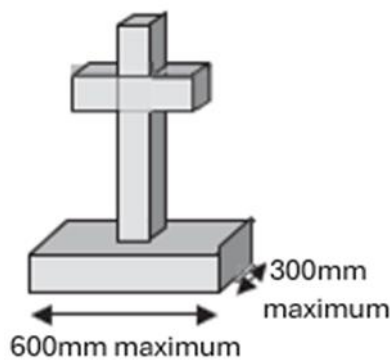
Regulation	Guidance
<p>No monument shall be permitted in the shape of a heart or figure. Loose slabs, stone tiles or tablets within the area of a grave are not permitted.</p> <p><b>d) Boulders</b> or memorials that incorporate a boulder require a faculty.</p>	<p><b>Vase Base:</b></p>  <p><b>Crosses:</b></p>   <p>Any request for a memorial not permitted by the Regulations should be the subject of a faculty to be considered by the Chancellor, based on the individual facts of the case and the advice of the Diocesan Advisory Committee. (see section 1.3)</p>

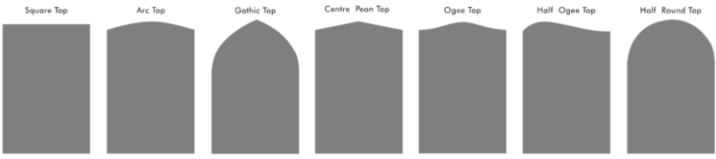
	Regulation	Guidance
	<p><b>e) Shapes of headstones</b> – headstones may be in any of the shapes illustrated</p>	<p><b>Guide to headstone shapes</b></p>  <p>The diagram illustrates seven distinct headstone shapes, each labeled above it: Square Top (a simple rectangle), Arc Top (a rectangle with a shallow, wide arch), Gothic Top (a rectangle with a pointed Gothic arch), Centre Peon Top (a rectangle with a shallow, pointed arch), Ogee Top (a rectangle with a double-arched top), Half Ogee Top (a rectangle with a top that is flat on one side and curved on the other), and Half Round Top (a rectangle with a semi-circular top).</p>
	<p><b>f) Flower Vases.</b> A fixed vase, in permitted stone material, not more than 300mm (12”) high x 200mm (8”) wide x 200mm (8”) deep with a memorial inscription may be placed in the approximate position where the headstone would have been, had there been one.</p>	<p>If a flower vase is desired, it is best incorporated in the base of a headstone or cross. Separate vases are not permitted, except where there is no headstone or cross; then a fixed vase with a memorial inscription may be permitted instead of a headstone. Vases should be incorporated in the base of a memorial as in the diagram.</p> <p>Free-standing plastic, metal and glass containers are not permitted as they are safety hazards.</p>
	<p><b>g) Inscription</b> or other <u>simple</u> decoration of a cross, plaque or headstone of normally permitted shape may be allowed by the Parish Priest.</p>	<p>Dedications should be simple, reverent and appropriate. The purpose of the epitaph is to identify the resting place of the person’s mortal remains, to honour the dead, to comfort the living and to inform posterity. The engraving should harmonise with the selected material. Inscriptions should be incised into the memorial or in relief (i.e. not inlaid or adhered). Lettering may be no more than 100mm in height and may be picked out in one or two colours from the following: black, gold, silver, grey or white. Flush or raised lead is also permitted. Plastic or other applied lettering is not permitted. Hand-cut lettering is encouraged. There are good examples in “The Churchyards Handbook”.</p> <p><a href="#">The Churchyards Handbook by Thomas Cocke - Paperback - 9780715143018</a></p> <p>On a form CR1 application you may be permitted to use Christian symbols, including a small cross, a Bible, or the ICTHUS sign, which is approved by the Parish Priest or Rural Dean receiving your application. You may be permitted to use a single flower or a spray of flowers or other plant (such as ears of corn) of appropriate size. Permission may be given for use of an emblem of appropriate scale commemorating a person who served in one of the Armed Forces. Regimental or other crests may only be used with the written permission of the regiment or organisation.</p>

	Regulation	Guidance
		<p>An original decorative design requires the permission of the Chancellor by faculty and will only be approved on a case-by-case basis if it is appropriate to the churchyard, not inconsistent with Christian doctrine and relevant to the commemoration of the deceased. It is the applicant's responsibility to ensure they are not infringing copyright if decorative motifs (such as book or film characters) are proposed. Such images should normally relate to a significant aspect of the person's life, and it is often helpful to refer to this in the inscription (e.g. 'farmer' or 'sculptor'). Christian imagery and texts are encouraged.</p> <p>Any decorative symbols or motifs should be incised into or in relief of the stone (i.e. not inlaid or adhered) and in total should not exceed 33% of the area of the surface of the headstone. They should be uncoloured, or coloured in a single colour in such a manner that the memorial is not discordant in the context of the church and churchyard.</p>
	<p><b>h) A family name</b> may be permitted on the reverse of a headstone.</p>	<p>This may be particularly relevant where a family has several memorials in the churchyard.</p>
	<p><b>i) QR codes</b> (which may be scanned using a mobile phone or other device to connect to a designated website), or lapidary stones are not permitted on memorials.</p>	<p>A memorial stone is a permanent record. Technology may change and it may not prove possible to control the website to which a QR code is linked.</p>
	<p><b>j) In the case of a headstone there is no trademark or advertisement</b> except for a reference to the mason (in lettering not higher than 15mm on the side or the reverse of the memorial).</p>	<p>The name only of a mason or firm may be inscribed low down at the side or on the reverse of a headstone or cross in unpainted and unleaded letters not more than 15mm in height. Similarly, if the PCC's regulations require it, a plot number may be inscribed at the side or on the reverse of a headstone or cross.</p>
	<p><b>k) Temporary items:</b>  No memorial shall include any sun dials or bird baths, obelisks, photographs, portraits or other similar mementoes or decoration such as solar or other lights.</p> <p>No loose items are to be left in the area of a grave.</p> <p>Items of value should not be left as these may be vulnerable to theft.</p>	<p>It is understood that in the days immediately following a burial, the family and friends mourning the loss of a loved one may wish to place items on a grave to commemorate their loved one and as tokens of their love. At the discretion of the Parish Priest, such items may be left in place for a reasonable period not normally exceeding 6 months. However, sensitivity should be applied, and the year's mind (anniversary of the death or funeral) should be avoided. However, the Parish Priest will ask the family to remove items which may be inappropriate, cause distress to other churchyard visitors, or be stolen, or which could be a danger (e.g. glass jars). Those items which are not in accordance with the Christian faith may only be placed with the express permission of the Parish Priest.</p>

	Regulation	Guidance
		<p>The PCC has responsibility for the maintenance of the churchyard and will take reasonable steps to notify families before removing items. This may include letters affixed to individual memorials. Where loose items are left on an unattended grave, the PCC may arrange for them to be placed in a suitable container for collection by the family.</p>
3.4.	<p><b>Extensions to memorials:</b>  The Parish Priest has delegated authority to permit extension additions to memorials provided that they are satisfied that:</p> <ul style="list-style-type: none"> <li>•the width of the extension is the same as the width of the base that it will abut</li> <li>•the depth of the extension is no more than 8" and no less than 6"</li> <li>•the height of the extension is the same as the height of the base to which it will abut</li> <li>•only one extension is allowed per memorial</li> <li>•the top of the extension is flush with the top of the base to which it abuts</li> <li>•the extension is made of the same stone and in the same colour as the base</li> <li>•a new foundation is installed onto which the base and extension are cemented</li> <li>•the new inscription lettering is in a style which matches the inscription on the original memorial</li> </ul>	<p>Further inscriptions may be added to the front of a headstone. Additional names and dates only may be added to the reverse. Should a more detailed inscription be desired on the reverse, a faculty will be required. Tiles or other tablets in a grave plot are not permitted, as they make maintenance difficult. If there is no remaining space, the base of a headstone may be extended as shown in the example opposite: If a headstone has no space for further inscriptions, it may be inscribed on the reverse. The stone may be turned and reset so that the more recent names appear on the front.</p> 
3.5	<p>The <b>removal of a memorial stone</b>, or its base, for the re-opening of a grave for further interment or its removal for repair, maintenance, inscription or (in case of damage beyond repair) like-for-like replacement is permitted with the consent of the Parish Priest through the CR2 form process. In all other cases a faculty is required. Memorials remain the property of the family.</p>	<p>Permission for removal is necessary for three reasons:</p> <ol style="list-style-type: none"> <li>i) For legal reasons as a faculty is required</li> <li>ii) On grounds of sensitivity to avoid causing alarm or assumption of vandalism or the worry that the grave itself may have been tampered with.</li> </ol>

#### 4. Flowers, plants and wildlife

	Regulation	Guidance
4.1.	<b>Fresh flowers</b> are encouraged. Artificial flowers are not permitted except as described in the Guidance.	Fresh flowers are encouraged as the symbol of the gift of creation and the brevity of life. Bulbs are similarly encouraged as a symbol of resurrection. Silk flowers are only permitted in exceptional circumstances, at the discretion of the Parish Priest, for example where rabbits destroy floral tributes. The PCC may remove dead and artificial flowers (including silk flowers that have deteriorated) to keep the churchyard tidy.
4.2.	The planting of perennial flowering plants, shrubs or trees (including conifers) is not permitted.	The grave should be kept level. The planting of flowering annual plants is encouraged as a further symbol of the gift of creation and the brevity of life. The planting of perennials, shrubs, bushes or conifers is not permitted, as they impede the maintenance of the churchyard. A growing shrub or tree roots will disturb the grave and may eventually damage the memorial stone or an adjacent grave. Families are encouraged to ask if there is a local scheme encouraging gifts of particular plants (e.g. rose bushes or specified trees) in specific areas of the churchyard.
4.3.	<b>Wildlife:</b> <i>The churchyard is a living sanctuary. In the bird song, scents and colours of the flowers is an affirmation of the continuity, vibrancy and resilience of life.</i> The Parish Priest and the PCC should have due regard for the wide range of flora and fauna in most churchyards. They should develop mowing and maintenance policies that respect and encourage the diversity of wildlife to flourish. There is good advice in <i>“The Churchyards Handbook”</i> , which has a list of other useful addresses.	The DAC issues guidance on managing a churchyard for wildlife. See: <a href="#">Churchyard Advice Leaflets - The Diocese of St Albans</a>

#### 5. Smaller memorials for children

	Regulation	Guidance
5.1.	Notwithstanding anything to the contrary in any Churchyard, the relevant Archdeacon may with regard to the death of a child aged 17 years or under at the date of death authorise the introduction of a gravestone, headstone or other memorial stone (“the memorial stone”) in respect of any grave of or memorial to such child which is smaller than permitted by such	The parish priest should consider whether a small memorial is likely to be a trip hazard in the proposed location.

	<b>Regulation</b>	<b>Guidance</b>
	Churchyard Regulations and of such appearance and design as he or she shall think fitting and appropriate in all the circumstances, provided that the memorial stone is not less than 10" (250mm) high, 12" (300mm) wide and 2" (50mm) thick.	

## 6. Burial of ashes

	<b>Regulation</b>	<b>Guidance</b>
6.1.	<b>An area or Garden of Remembrance</b> may be set aside in a Churchyard exclusively for the burial of ashes. A faculty is needed to designate an area for the burial of ashes and to make provision for individual memorials, except in the case of a small parish in accordance with the provision in Regulation 6.3. Memorial plaques must comply with the provisions in Regulation 6.4. Except by the authority of a faculty no other monument or any vase shall be introduced into such an area.	<p>Normally, ashes may only be buried in a part of the churchyard set aside for the burial of ashes or in an existing grave with the consent of the Parish Priest.</p> <p>In exceptional circumstances, the Parish Priest may allow interment in other parts of the churchyard if this is reasonably practical. This is sometimes permitted if the family wishes to have a standard sized headstone rather than a memorial plaque.</p> <p>To set up a Garden of Remembrance and to establish local practice, a faculty is needed (but see paragraph 6.3 for small parishes).</p>
6.2.	<b>Ashes after cremation</b> must not be scattered or strewn but shall be buried in a suitable perishable or biodegradable container or poured into the ground and covered.	
6.3.	<b>The Archdeacon</b> may authorise a part of the Churchyard to be set aside without the authority of a faculty in accordance with the Guidance.	<p><b>If:</b></p> <ul style="list-style-type: none"> <li>• the churchyard is open for further burials;</li> <li>• the parish in which the churchyard is situated has less than 600 persons on the local electoral roll; and the Parish Priest and the PCC both agree that an application be made to the Archdeacon under this regulation; and</li> <li>• the Parish Priest and the PCC are able to satisfy the Archdeacon that the number of burials of ashes does not average more than three each year during the previous three years; and</li> <li>• memorials will be in accordance with Regulation 6.4:</li> </ul> <p>the Archdeacon at his/her entire discretion may authorise a part of the churchyard to be set aside without the authority of a faculty.</p>

	<b>Regulation</b>	<b>Guidance</b>
6.4.	<b>Memorial Plaques</b> (over ashes) shall be flush with the turf and measure not more than 300 mm (12") by 300 mm (12").	<p>The methods of commemoration of the names of those whose ashes are buried in a Garden of Remembrance vary according to the details permitted by the faculty. Books of Remembrance in the church are a good way to remember those whose ashes are buried in the Garden of Remembrance. The Garden can then be left as a grassed area.</p> <p>Where memorial stones are permitted by the faculty, these may be introduced with the permission of the Parish Priest. The stone (incorporating a vase if permitted):</p> <ul style="list-style-type: none"> <li>• should be of a material permitted for memorial stones under the Regulations (see paragraph 3.2 above); and</li> <li>• should be of the same size (maximum 300mm x 300mm (12" x 12")), colour and material as other memorial stones in the same Garden of Remembrance and should respect the character of the same Garden of Remembrance as a whole;</li> <li>• should be flush with the turf and should not be covered with Perspex or other protective material;</li> <li>• should not be placed in churchyard walls.</li> </ul>

## 7. Churchyard Maintenance, and PCC responsibilities and powers

	<b>Regulation</b>	<b>Guidance</b>
7.1.	<b>Except in cases of closed churchyards, the Parochial Church Council ("PCC")</b> is responsible under the Parochial Church Councils (Powers) Measure 1956 for the care and maintenance of the Churchyard including its safety and appearance.	<p>The Parish Priest and the PCC have overall responsibility for issues relating to the care, maintenance, and safety of churchyards. They have authority to make safe or lay flat leaning or loose stones and memorials to make them safe. Also, the PCC have the authority to remove loose and unauthorised items. Memorials should be inspected regularly by the Churchwardens and tested by hand. If a memorial is found to be unsafe, the PCC should take steps to notify the family. A faculty is required to carry out widespread remedial work to memorials where the family cannot be traced. Where possible, notice will be given by the PCC before work is carried out. However, in cases of emergency the PCC has authority to lay a gravestone flat temporarily, or to fence the area with hazard warning tape for safety.</p> <p>The PCC's requirements for maintenance and repair are limited by the funds at its disposal, therefore the church welcomes donations towards the upkeep of the churchyard. Families and friends are likewise encouraged to maintain their loved ones' graves and the memorials placed upon them.</p> <p>Where the churchyard is closed for further new burials by Order in Council, the PCC's responsibility for maintenance of the closed churchyard may be transferred to the local authority.</p>

	<b>Regulation</b>	<b>Guidance</b>
7.2.	<b>The Parish Priest and PCC</b> must maintain an up-to-date plan of the churchyard.	<p>This has been a requirement in the Churchyard Regulations since at least 2004. PCCs are asked to make every effort to record older burials on the churchyard plan, to avoid distress where a grave cannot be located.</p> <p>A larger-scale measured plan should be drawn up and the positions of known graves marked, including reference to double-depth graves where appropriate. It is helpful if a note can be added of any grave spaces reserved by faculty. The area of any Garden of Remembrance should be marked, and a record kept of the layout of burials.</p> <p>The churchyard plan should be kept with the burial register and regularly updated. Some parishes display a copy of the plan in or near the churchyard.</p>
		<b>Grave Trusts:</b> In some cases, money has been left in trust for the maintenance of the churchyard and the PCC benefits from the income of this trust. It may have an obligation to maintain a grave and its memorial in accordance with the terms of the trust.

## 8. Discretionary Procedure

	<b>Regulation</b>	<b>Guidance</b>
		The Chancellor will consider proposals which fall outside the Regulations but are not expressly prohibited.

## 9. Exhumation

	<b>Regulation</b>	<b>Guidance</b>
		<p>Exhumation of a body or cremated remains is only permitted where there are exceptional circumstances to justify it; for example, burial in the wrong grave space. Convenience of visiting the grave will not be accepted as a sufficient ground for allowing exhumation.</p> <p>A faculty is required for exhumation from consecrated ground, irrespective of the proposed site of re-interment and whether or not it is consecrated. If an exhumation is from unconsecrated ground outside the jurisdiction of the Court a licence from the Ministry of Justice is required instead.</p> <p>The Diocesan Registrar must be consulted in any case of this kind.</p>